

### BENEFITS

#### Highest Efficiency

SunPower™ Solar Panels are the most efficient photovoltaic panels on the market today.

#### More Power

Our panels produce more power in the same amount of space—up to 50% more than conventional designs and 100% more than thin film solar panels.

#### Reduced Installation Cost

More power per panel means fewer panels per install. This saves both time and money.

#### Reliable and Robust Design

Proven materials, tempered front glass, and a sturdy anodized frame allow panel to operate reliably in multiple mounting configurations.



SPR-308E-WHT-D

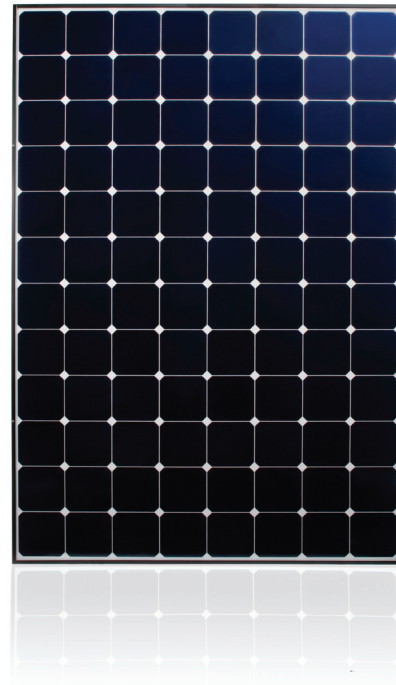

The SunPower™ 308 Solar Panel provides today's highest efficiency and performance. Utilizing 96 back-contact solar cells, the SunPower 308 delivers a total panel conversion efficiency of 18.9%. The panel's reduced voltage-temperature coefficient and exceptional low-light performance attributes provide outstanding energy delivery per peak power watt.

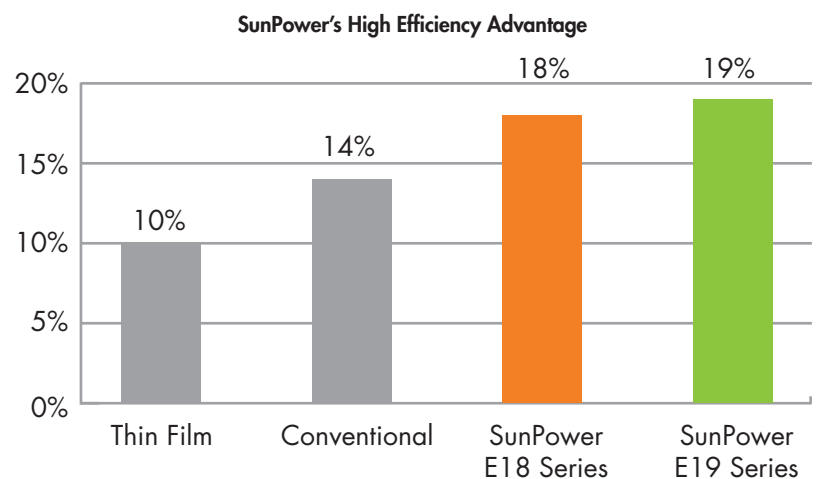

### Electrical Data

Measured at Standard Test Conditions (STC): irradiance of 1000W/m<sup>2</sup>, AM 1.5, and cell temperature 25° C

Peak Power (+5/-3%)	P <sub>max</sub>	308 W
Efficiency	η	18.9 %
Rated Voltage	V <sub>mpp</sub>	54.7 V
Rated Current	I <sub>mpp</sub>	5.64 A
Open Circuit Voltage	V <sub>oc</sub>	64.3 V
Short Circuit Current	I <sub>sc</sub>	6.02 A
Maximum System Voltage	UL	600 V
Temperature Coefficients	Power (P)	-0.38% / K
	Voltage (V <sub>oc</sub> )	-176.6mV / K
	Current (I <sub>sc</sub> )	3.5mA / K
NOCT		45° C +/-2° C
Series Fuse Rating		15 A

### Mechanical Data

Solar Cells	96 SunPower all-back contact monocrystalline	
Front Glass	high transmission tempered glass	
Junction Box	IP-65 rated with 3 bypass diodes Dimensions: 32 x 155 x 128 (mm)	
Output Cables	1000mm length cables / MultiContact (MC4) connectors	
Frame	Anodized aluminum alloy type 6063 (black)	
Weight	41 lbs. (18.6 kg)	

### I-V Curve

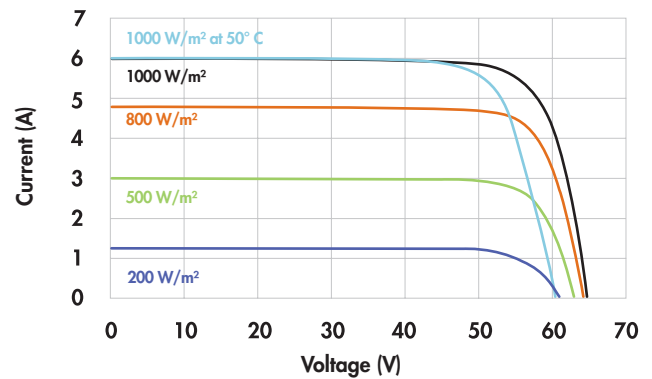

### Tested Operating Conditions

Temperature	-40° F to +185° F (-40° C to + 85° C)
Max load	113psf 550 kg/m <sup>2</sup> (5400 Pa), front (e.g. snow) w/specified mounting configurations 50 psf 245 kg/m <sup>2</sup> (2400 Pa) front and back – e.g. wind
Impact Resistance	Hail 1 in (25 mm) at 52mph (23 m/s)

### Warranties and Certifications

Warranties	25 year limited power warranty 10 year limited product warranty
Certifications	Tested to UL 1703. Class C Fire Rating

### Dimensions

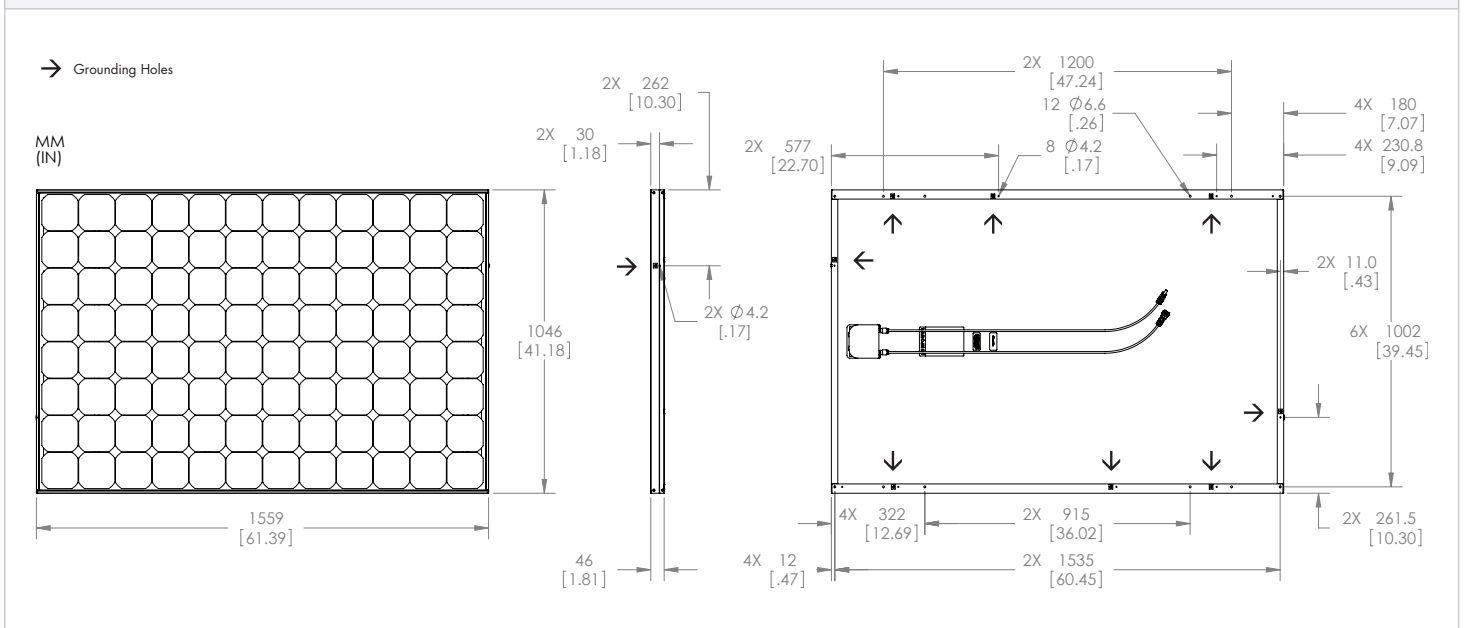

**CAUTION: READ SAFETY AND INSTALLATION INSTRUCTIONS BEFORE USING THE PRODUCT.**  
Visit [sunpowercorp.com](http://sunpowercorp.com) for details